



1-888-PbS-PbSe  
(727-7273)

## 1. 室温硒化铅探测器系列 PbSe RT

F-FA-FS 系列和 FM-FAM-FSM 密封系列

特性：

Hermetically Sealed Packages  
Room Temperature Operation  
Custom Wavelength Response  
Custom Test  
Hybrid Amplifiers  
2 Year Warranty  
Customized Filters Available  
Custom Packages

电子规格：

Test Conditions at 23°C - Typical	F & FM	FA & FAM	FS & FSM
D* (Pk.,1000,1) x 10 <sup>10</sup>	.1 - .3	.4 - .5	.6-1.5
Peak Wavelength Response - Microns Typ	3.8	3.8	3.8
Time Constant - Microseconds	2 - 5	2 - 5	2 - 5
Resistance - Megohms	.1 - 4	.1 - 4	.1 - 4

激活面积规格：

Code Number	Active Area		Bias Voltage	Typical VW-1	Package Size
	Inches	mm	Typical		
1	.040	1	50	1-4x10 <sup>4</sup>	TO-5 & TO-46
2	.080	2	100	.5-2x10 <sup>4</sup>	TO-5
3	.120	3	150	.4-1x10 <sup>4</sup>	TO-5
5	.200	5	250	3-6x10 <sup>3</sup>	TO-8
10	.400	10	500	600	TO-3

联系电话：13809036065 张先生

机械尺寸规格：

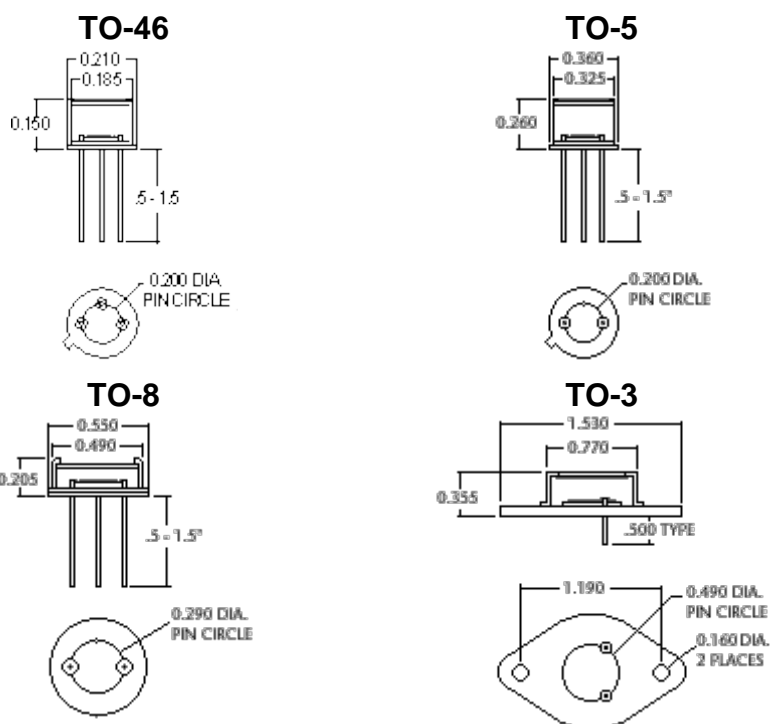

如何订购：

Select the proper lead selenide electrical type (F; FM) and match it with the proper mechanical and package code number. Example: FM-1-5, FM-5-8. The active areas listed are considered standard sizes. Special size plate cells are available upon request.

## 2.电子制冷硒化铅探测器系列 PbSe TEC Cold

### G-G2-G21 系列

特性：

Hermetically Sealed Packages  
 Custom Wavelength Response  
 Custom Test Procedure  
 Custom Design Service  
 2 Year Warranty  
 Customized Filters Available

电子规格：

Test Conditions at 25° C	G	G2	G21
D* (Pk.,1000,1) x 10 <sup>10</sup>	1-3	1-3	2-4
Peak Wavelength Response - Microns	4.3	4.4	4.6
Time Constant - Micro Seconds	5-10	15	20
Resistance - Megohms	.2 - 7	.2 - 10	.2 - 15
Operating Temperature - °C	-25	-35	-50
Cooler Power	1.2V/2A	.8vV/1.3A	2.2V/1.2A

激活面积规格：

Code Number	Active Area		Bias Voltage	Typical VW-1 Responsivity			Package Size
	Inches	mm		Typical	-25	-35	
1	.040	1	50	4-6x10 <sup>4</sup>	6-10x10 <sup>4</sup>	10-15x10 <sup>4</sup>	TO-5-37-8-66
2	.080	2	100	2-3x10 <sup>4</sup>	3-5x10 <sup>4</sup>	5-8x10 <sup>4</sup>	TO-5-37-8-66
3	.120	3	150	1-2x10 <sup>4</sup>	2-3x10 <sup>4</sup>	3-5x10 <sup>4</sup>	TO-5-37-8-66
5	.200	5	250	.8-1x10 <sup>4</sup>	NA	NA	TO-8-66
10	.400	10	500	4-6x10 <sup>3</sup>	NA	NA	TO-3

机械尺寸规格：

联系电话：13809036065 张先生

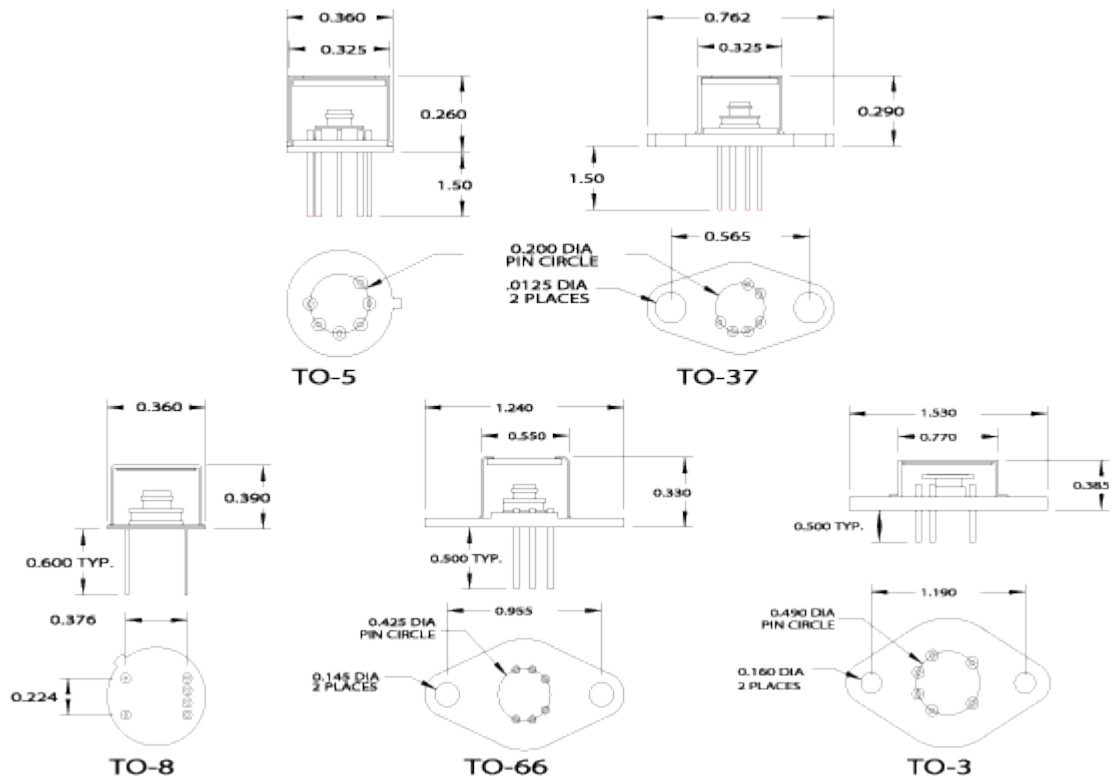

如何订购：

Select the proper electrical type (G, G2, G21, GS21), and match it with the proper mechanical and package code number. Example: G-2-37, G2-1-5, G21-2-8. The active areas listed above are considered standard sizes. Special sizes are available upon request. GS - Select High Performance PbSe - Contact NEP for availability.

探测器术语解释：

**Background Temperature**

The effective temperature of all radiation sources viewed by the detector, excluding the signal source.

**Bias Voltage**

The voltage applied to the detector circuit, normally DC volts; sometimes called optimum bias for values which give optimum signal-to-noise ratios and maximum bias for values which produce the maximum signal voltage output, it is called reverse bias when applied to the P-N junction of solid crystal detectors in a reverse mode to increase the speed of response or to increase the long wavelength response.

**Dark Current**

The measured current in a detector circuit when operated with no signal radiation incident on the detector element

**Dark Resistance**

The ratio of the DC voltage across the detector to the DC current through it when no radiation is incident on the detector.

**D-Star (D\*)**

A relative measure of sensitivity used to compare the detecting capabilities of different detectors. D\* is the signal-to-noise ratio at a specific electrical frequency with a 1 Hz bandwidth when radiant power is incident on the detector active area.

**Load Resistor**

A resistance element that is in series with the detector element and bias voltage; typically matched to the detector's dark resistance

**Noise-Equivalent-Power (NEP)**

The amount of required signal radiant

**Resistivity**

The square areas resistance of a thin film detector, where L and W are equal; L being the separation between the electrodes and W is the length of the detector active area. Resistivity is a function of the detector element temperature and the level of irradiance.

**Responsivity**

A value indicating signal output from radiation incident on the detector element. The value where the detector has a maximum spectral response is called peak responsivity. It is a function of detector area, wavelength, and circuit parameters.

**Rise Time-Fall Time**

Rise time and fall time are the times in seconds required for the signal response to rise from 10% to 90% and fall from 90% to 10% of the maximum observed signal value. This happens when detectors are exposed to pulses of signal radiant power.

**RMS Noise Voltage or Current**

The element of the electrical output (voltage or current) which is incoherent with the signal radiant power, usually measured with no signal radiation incident on the detector element and is related to the detector area. It is the function of frequency response, noise equivalent bandwidth, operating temperature, other circuit parameters such as the load resistor, and in some cases detector solid angle and background temperature.

**RMS Signal Voltage or Current**

The element of the electrical output (voltage or current) which is coherent with the monochromatic or blackbody

联系电话：13809036065 张先生

power on the detector element area to yield a signal-to-noise ratio of one, and indicates the minimum detectable radiation level; the smaller the NEP value, the better the performance.

#### **Photoconductive Detector**

A photon detector which exhibits increased conductivity with incident radiant power.

#### **Photovoltaic detector**

A photon detector with a p-n or p-i-n junction which converts radiant power directly into electrical current; also called a photodiode.

input signal radiant power. It is a function of electrical frequency, signal power, spectral characteristics, operating temperature, and other circuit parameters such as the load resistor and bias voltage.

#### **Spectral Response**

Most of the time this is shown as  $D^*$  vs. Wavelength, usually presented as a graph showing relative signal as a function of wave length of the incident radiant power.

#### **Time Constant**

A measurement of a detector's speed of response when the detector is exposed to a square wave pulse of radiation. The rise time constant is the time required for the signal voltage to reach 0.63 times its asymptotic value. The decay time constant is the time required for the signal voltage to decay to 0.37 of the asymptotic value. This can also be measured by determining the chopping frequency at which the signal response is 0.707 of its maximum value.

响应曲线：

